

Granulator Bed Knife Form

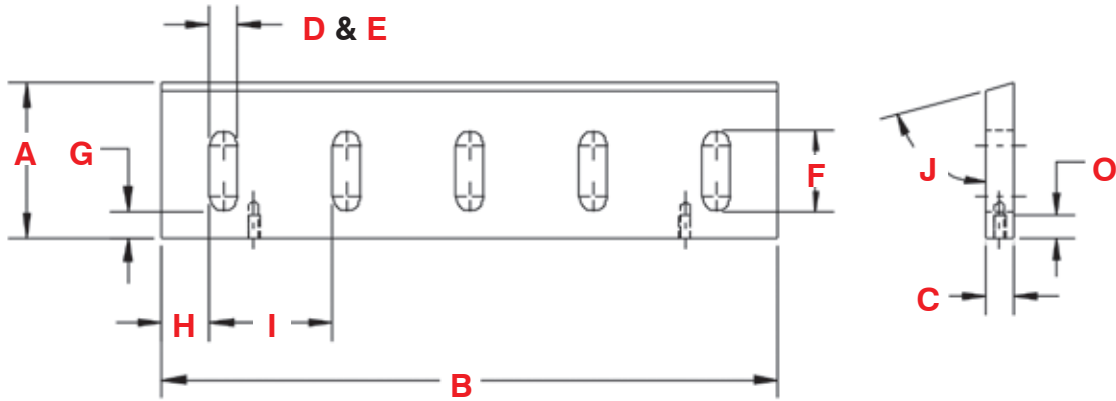

SPECIFY:

Press Make: _____
 Press Model: _____
 OEM# (if available): _____

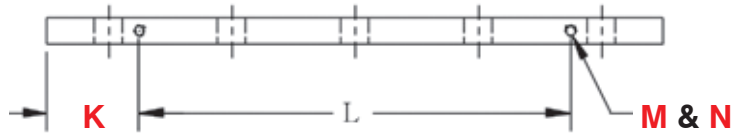

1) Note any part numbers or markings on the knife:

A. Height: _____
 B. Length: _____
 C. Thickness: _____

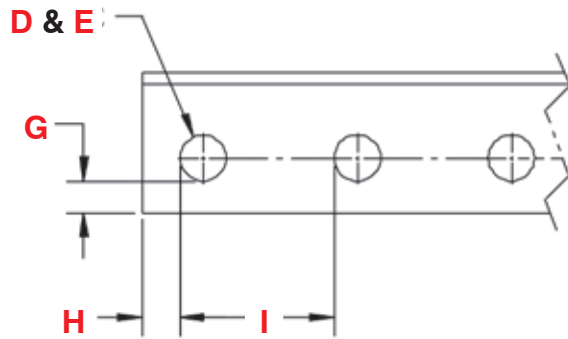

2) Hole/Slot information:

Type of holes: _____
 D. Quantity of holes: _____
 E. Slot width/Hole diameter: _____
 F. Slot length: _____
 G. Bottom edge to hole/slot edge: _____
 H. End to first hole/slot edge: _____
 I. Typical hole/slot spacing: _____
 J. Bevel angle: _____

3) Tapped hole information:

K. End to tapped hole center: _____
 L. Tapped hole center to center: _____
 M. Quantity of tapped holes: _____
 N. Tapped hole size & pitch: _____
 O. Tapped hole depth: _____

4) Note any special features:

Date: _____ Quantity: _____ Phone: (_____) _____ Fax: (_____) _____

Name: _____ Title: _____

Company Name: _____ Email: _____

Address: _____

City: _____ State: _____ Zip: _____



www.imscompany.com

fax order toll-free (USA & Canada)

1.888.288.6900

phone order toll-free (Mexico)

001.888.304.1307

tech support toll-free (USA & Canada)

1.866.467.9001

e-mail

sales@imscompany.com

phone order toll-free (USA & Canada) **1.800.537.5375**